

SERDP Hydrogen Re-Embrittlement DoE Test Plan Status

By:
Stephen Gaydos
Boeing – St. Louis

May 17, 2007
DoD Metal Finishing Workshop – Chromate Alternatives for
Metal Treatment and Sealing
Hilton Garden Inn – Layton, UT

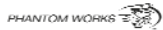

1



DoD Metal Finishing Workshop May 2006 – Washington D.C.

- Workshop Identified Barriers for Implementing Cadmium Plating Alternatives
- Hydrogen Embrittlement Testing Was Identified as a Major Barrier
 - Need to Verify that Alternative Coating Process is Non-Embrittling to HSS (Called Embrittlement Testing)
 - Need to Verify that Maintenance Chemicals on HSS with Alternative Coating Do Not Embrittle the HSS (Called Re-Embrittlement Testing)

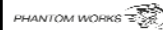

2



ASTM Embrittlement Test

- Process Control Test Conducted per ASTM F519 on Plated/Coated (and Baked) Specimens
 - 7 Specimens to Choose From
 - 1a.1, 1a.2, 1b, 1c, 1d, 1e, 2a (Evaluated by Boeing)
 - 1b Rarely Used – Not Tested
 - 1d Most Sensitive
 - 2a Least Sensitive
 - 1e Loses Sensitivity at Low H Levels
 - Sustained Load (SL) Method is Typical Process
 - Specimens Typically Loaded at 75% NFS for **200 Hours**
 - Incremental SL (ISL) Methods Being Evaluated But Not Widely Accepted
 - Cadmium Replacement Barrier Identified Test Time
 - **Need a 24 Hour Test Method**

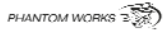

3

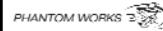
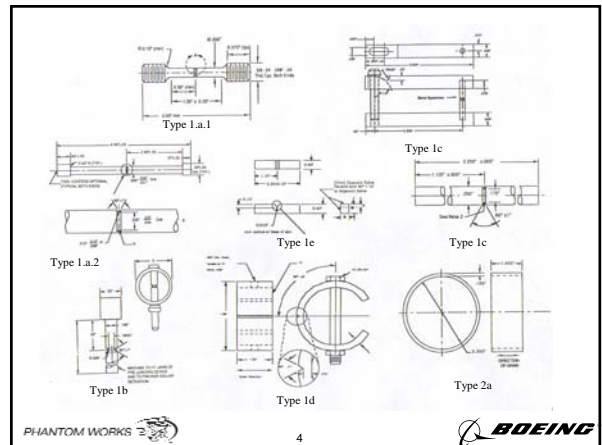

4



ASTM F 519 Specimens



5



ASTM Re-Embrittlement Test

- ASTM F 519 – Annex A5
 - Annex A5 Describes Different Test Method Guidelines
 - "... the testing protocols described in this section (Annex A5) should only be used as a guideline. . . "
 - 7 Specimen Types
 - Aggressive Chemicals
 - » Hold at 45% NFS while Wet for ?? Time, Then Rinse and Dry and Hold at 75% NFS for 200 hrs
 - Passive Chemicals
 - » Hold at 45% or 65% NFS while Wet for 150 hrs
 - Solution Volume, Temperature and Concentration are Undefined
 - Cadmium Replacement Barrier Identified
 - **Need a Simplified and Standard Test Method to Re-Qualify All Maintenance Chemicals That are Currently Qualified with Cadmium Plated HSS Using the Alternative Coating on HSS**
 - Potential Cost Savings is Significant

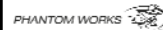

6



Maintenance Chemical Qualification

Hydrogen Re-Embrittlement -

- ASTM F519, Test Specimens
 - LHE Cadmium Plated High Strength Steel (HSS)
- Wet Notch - 150 hrs at 45% NFS
 - Concentrated and Diluted

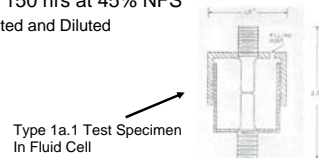

Type 1a.1 Test Specimen
In Fluid Cell

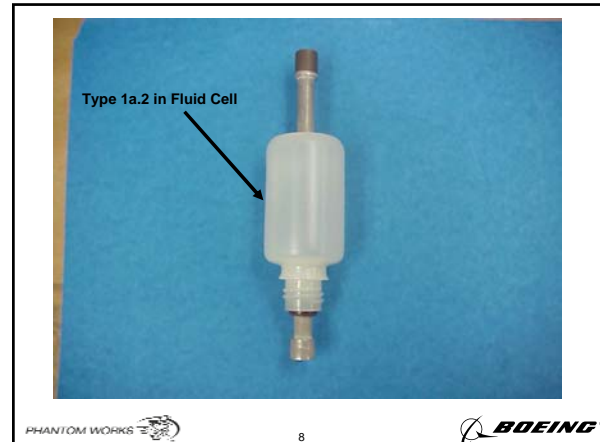

Hydrogen Re-Embrittlement

- Hydrogen Re-Embrittlement Mechanism
 - It's a Form of Corrosion
 - Cathodic Reaction Occurs on Steel
 - $2H^+ + 2e^- = H_2$ (gas)
 - Anodic Reaction Occurs on Sacrificial Cadmium Coating
 - $Cd = Cd^{2+} + 2e^-$
 - Parts Affected by Hydrogen Re-Embrittlement Typically Cannot be Baked to Remove Hydrogen
 - Parts are typically assembled on equipment
 - Baking is 375°F x 24 hrs.
- Test Data Scatter is Common
 - Appears to be Testing Coating Integrity or Test Set-Up and Not The Cleaner

Basic Mechanism in Hydrogen Re-Embrittlement

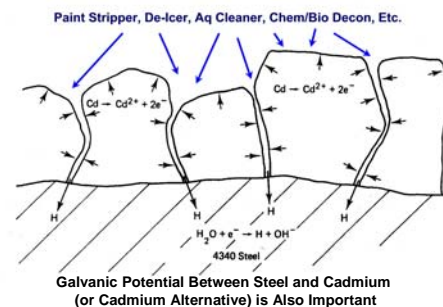

Re-Embrittlement Test Issues

- Not Standardized Across the Industry – Variations of ASTM Annex A5 Used
 - Various ASTM F519 Specimens Used
 - Type 1.a.1, 1.a.2, 1b, 1c, 1d, 1e, and 2a
 - Various Specimen Immersion Methods
 - Wet for 150 hrs, Wet Than Dry, Concentrated or Diluted Chemicals
 - Volume of Fluid, Temperature
 - Various Loading Methods
 - Tension, Bending, Sustained Load, Incremental Step Loading (24 hours)
 - 45%, 65%, 75% NFS, 80%YS for 150 or 200 hrs

Re-Embrittlement Testing Is Our Tower of Babel



The Confusion of Tongues by Gustave Doré (1865)

Status

- \$50K Spent to Order 390 Test Specimens
- Plating, Inspecting and Testing by Outside Labs Will Easily Consume the Remaining \$50K of SERDP Funds
 - ARL and Boeing Providing Labor to Make-Up Difference
 - Additional Support Would Be Beneficial
- Cadmium Plating of Test Specimens to Begin by July 2007
- Phase I DoE Testing Begins August 2007

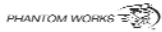

19



Expected Outcome from Phase I

- Determine Which Specimen Type Gives Reproducible and Meaningful Results
- Determine What Strength Level of Steel is Non-Embrittling
- Determine The Load That Gives Reproducible and Meaningful Results
- Identify the Test Parameters That Allows Cadmium Plated Steel to Pass Test in Water
- Use Information from Phase I to Conduct Phase II DoE Tests

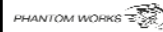

20



Round-Robin DoE Test Coordinators

- Scott Grendahl – ARL, Aberdeen
 - ASTM Task Group Leader for Revising ASTM F 519 Annex A5
- Ed Babcock – Boeing, Mesa
 - ASTM Task Group Leader for Revising ASTM F 519 Main Specification
- Steve Gaydos – Boeing, St. Louis
 - ASTM F07.04 Subcommittee Chairman for Hydrogen Embrittlement Test Methods

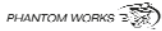

21

